



H₂ Filter

Fuel Cells - ICE Conversions - Dual Fuel

208 Series

208 Series: Specifically designed for H₂ service, the 208 series in-line filter offers a simple and durable filter for use on hydrogen fuel systems.

Operating at pressures up to 700 bar.

A wide range of filtration levels and porting are available, be-spoke configurations are also available upon request

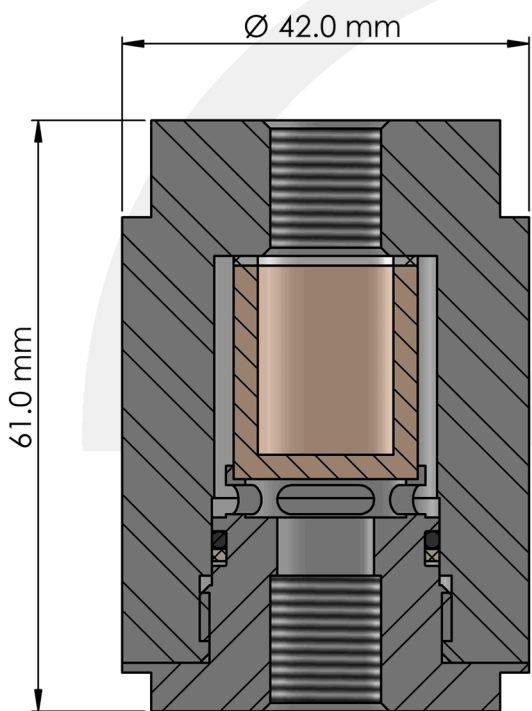

Specification	
Max Inlet Pressure	700 Bar
Filtration options	5, 10, 15, 25 and 40 Micron options
Materials of Construction	Stainless Steel 316L
Design Proof Pressure	1400 bar
Weight	450 grammes
Porting	1/4" BSP 1/4" NPT 9/16" SAE custom configurations

Features and Benefits:

- 700 bar max Inlet pressure
- H₂ Ready
- Simple and durable design
- Range of filtration level and port options available
- Sintered SS316 Filter element

Part Number Generator

208 — X 0 X

Porting	
0	1/4" BSP
1	1/4" NPT
2	9/16" - J1926-1 SAE

Filtration Level	
0	5 micron
1	10 micron
2	15 micron
3	25 micron
4	40 micron

Example part number: 208-103 : 1/4" NPT porting, 25 micron filter element

Custom porting & filtration levels available, please contact our sales office or visit our website for details.

Regular service schedule recommended.

